

RDC 210

Direct Current Tachometer generator



- Applications :**
- Industrial applications
 - Machine tools
 - Robots

- Description :**
- Dc tachometer generator : rotor/stator set
 - Permanent magnet excitation
 - Collector on opposite of mounting side
 - Several mechanical options (IP 00 - IP 68)
 - Short version
 - **SILVER COMMUTATOR**

DIAGRAM

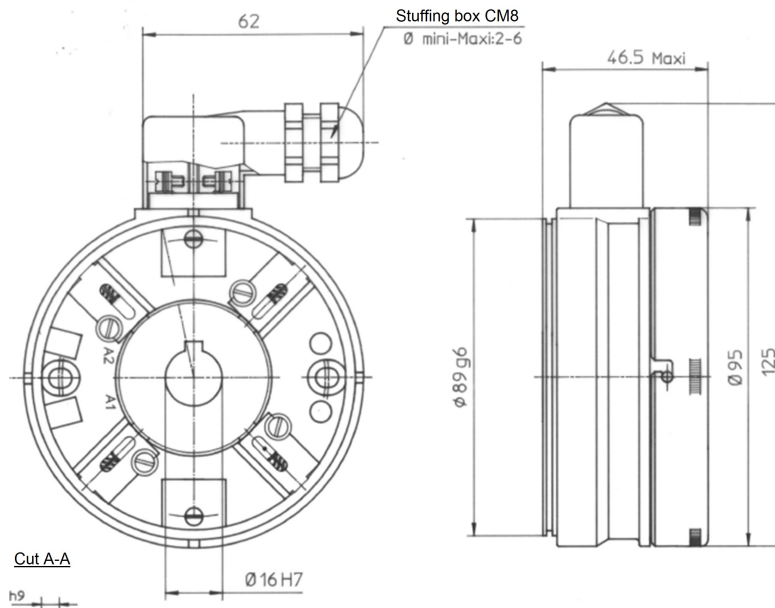

MAIN CHARACTERISTICS

DESIGNATION	SYMB	VALUES
Max. speed (mechanical)	n_m	6000 rpm
Moment of inertia	J	0,7 km cm ²
No load driving torque	M_r	$\leq 0,5$ N.cm
Maximum E.M.F	E_m	120 V
Maximum linearity error	ΔE	$\leq 0,15$ % E_T
Overall ripple rate (peak to peak)	ΔE_c	$\leq 0,5$ % E_c
Rotation harmonics (f=2 p.n)	ΔE_p	$\leq 0,05$ % E_c
Slot harmonics (f=Z.n)	ΔE_z	$\leq 0,45$ % E_c
Calibration precision	ΔE_o	± 2 % E_{T_0}
E.M.F. tempertaure drift		
- not compensated	ΔE_c	0,03 % °C
- compensated		
Time constant	C_t	0,45 ms
Filter : Time constant of filter		0,1 ms
Load current		3 mA
Speed		3000 rpm

CONSTRUCTION DETAILS

Number of poles	2p	4
Number of armature slots		33
Number of commutator blades		33
Insultation class		B (IEC 34-1)
Operating temperature		-20°C / +80 °C
Climatic protection		C _a (IEC 68-1)
Protection degree		IP 00 (IEC 34-5) IP 68 (DIN 40050)
Direction of rotation		reversible
Excitation : Aimants permanents		SmCo

Weight	0,5 kg
---------------	---------------

MECHANICAL OPTIONS

Standard	ARMATURE BORE Ø d (mm)		MOTOR CENTERING END FRAME Ø D (mm)		ARMATURE CLAMPING DEVICE
	Max.	Min.	Standard		Key or expanding device
16 ^{H7}	16	8	89		

OPTIONS

- For incorporation purposes : IP 00
- Closed version : IP 44
- Enclosed version : IP 68
- Conic bore

AVAILABLES OPTIONS

- No adaptation possible



Markings and polarity of terminals (cables) for counter-clockwise rotation viewing the mounting face

A1 : +
A2 : -

ELECTRICAL OPTIONS

DESCRIPTION	SYMB	UNIT	VALUES				
			Min.	7	10	14	Max.
E.M.F. at 1000 rpm	E_n	V	5	7	10	14	20
Voltage gradient	C _v	V/rpm	0,005	0,007	0,010	0,014	0,02
Armature resistance	R _a	Ω	5	11	22	45	80
Max thermal load	I _{th}	mA	280	190	136	92	74
Max. allowed speed	n _a	rpm	6000	6000	6000	6000	6000

BRUSHES

GRADE	CODE	APPLICATION LIMITS	DIMENSIONS	NUMBER
EG - Electrographite	/0002607	Special applications, on request	6 x 4 x 11 mm	4
CA - Silver-graphite	/0001397	STANDARD for normal use at E.M.F < 300 v		

PRODUCT DESCRIPTION

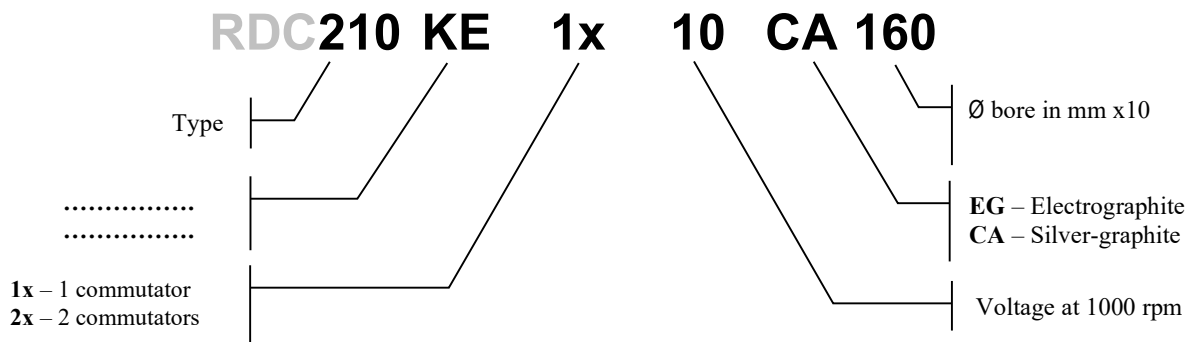

When inquiring, please advise the serial number of the tachogenerator to be replaced.